

# Charging the future for a Greener Planet



Electric 2W – Adoption from 0 to 100



**redseer**  
Strategy Consultants

Dubai. Bangalore. Delhi. Mumbai. Singapore. New York

January 2023

© 2023 Redseer Strategy Consultants Confidential and Proprietary Information

# Table of Contents

<b>1.</b>	<b>Tapping the EV Potential in India</b>	04-10
1.1	Where it all began globally?	04-05
1.2	India's EV revolution with E2W as frontrunner	05-06
1.3	E2W adoption in India: A timeline	07
1.4	Indian government's green push: Key initiatives	07-08
1.5	Evolution of Market penetration	09-10
<b>2.</b>	<b>E2W Provides Level Playing Field for the New Entrants</b>	11-12
2.1	Lots of room for everyone to grow	11
2.2	E2W - A level playing field	12
<b>3.</b>	<b>Localisation and Vertical Integration inPlay</b>	13-16
3.1	Localisation of EV supply-chain ecosystem	13
3.2	Brands leading the way for EVs in India	14
3.3	Verticalization of E2W manufacturing in India	14-16
<b>4.</b>	<b>Supply-Side Challenges in EV Adoption</b>	17-23
4.1	Battery pack, a critical part of vehicle powertrain	17-18
4.2	Motor, Chassis, Mechanical Components, and others	19
4.3	Battery management system & safety	20-21
4.4	Charging Infrastructure - A must for mainstreaming EVs	21-23
<b>5.</b>	<b>Making EVs Financially Viable</b>	24
5.1	Initiatives towards Affordability	24
<b>6.</b>	<b>Omni Channel Play Imminent</b>	25
<b>7.</b>	<b>Four A's of E2W eco System Growth</b>	27-28
	Glossary	27
	Authors	28

## Foreword

As the demand for sustainable transportation solutions continues to grow, the electric 2-wheeler market in India is also poised for significant expansion. With an increasing focus on reducing carbon emission and combating air pollution, the adoption of electric 2-wheeler (E2W) is seen as a vital step towards a cleaner and more sustainable future.

The Indian government has also recognised the need to transition to electric vehicles, and has implemented a number of incentives and policies to encourage the adoption of E2Ws. These efforts, combined with technological advancements and cost-economies of the vehicles, are paving the path for a strong growth of the sector in India.

2022 was a major inflection point for the electric 2-wheeler market in India, bringing it from the fringes to the mainstream. No longer are EVs something that one has only heard of – they are visible on the roads, one's acquaintance owns one and are a viable consideration option when one is in the market for a new vehicle.

This report aims to provide an understanding of the dynamics of this industry. While we have attempted to describe the key market trends, market size, and forecast, competitive landscape, and policy and regulatory developments along with insights into the challenges and opportunities faced by the industry, as well as the key players shaping the market, our objective is that we demystify this market and bring it further mainstream. Overall, the report aims to be a valuable resource for anyone seeking to understand the current state and future potential of the electric two-wheeler market in India.



**Anil Kumar**  
Founder and CEO

## 1. Tapping the EV Potential in India

For decades, the word 'mobility' meant bikes, cars and trucks, a space to park, the price at the pump and city streets. However, cost, convenience, user experience, safety, and the environment gradually became an important part of the scope of mobility. The mobility industry had to reimagine the sector as climate change, global warming, and other environmental concerns became issues that needed to be addressed immediately. Eventually, several governments and consumers realised the need for low-emission commuting options to stop fossil fuel-driven vehicles from endangering the planet. Thus, Electric Vehicles (EVs) took centre stage as a more sustainable alternative for the environment.

Although EVs have existed for many decades, they came under the spotlight when more prominent companies joined the bandwagon. One of the prominent names in the EV sector is Tesla. In 2008, it released its first car, the completely electric Roadster, which achieved 245 miles (394 km) on a single charge. Similarly, several automakers started rolling out EVs rapidly, increasing these vehicles' penetration significantly in the past few years. Although the road to achieving 100% electric mobility is still bumpy, there is a visible shift towards clean energy mobility.

### 1.1 Where it all Began Globally?

**“Governments worldwide have been giving EVs a push through subsidies, regulations, significant collaborations and partnerships.”**

The global EV story began between 1832 and 1839 when countries began toying with the concept of a battery-powered vehicle. Later in the 1960s-70s, the world first realised the need for alternative fuel to gasoline due to soaring oil prices. Since then, there has been no looking back.

By 1975, prominent companies started focusing on experimentation. For instance, General Motors developed a prototype for an urban electric car displayed at the Environmental Protection Agency's First Symposium on Low Pollution Power Systems Development in 1973. Likewise, the American Motor Company produced electric delivery jeeps from the United States Postal Service used in a 1975 test program. By 1990-2005, EV transition gained further momentum with government regulations and a push for EVs from policymakers. Finally, from 2006-2013, there was advancement in infrastructure, and from 2013 mass adoption has taken off.

Further, environmental concerns drove electric vehicles forward as new federal and state regulations, in the US, began to change things substantially. E.g., the passage of the 1990 Clean Air Act Amendment and the 1992

Energy Policy Act, in addition to new transportation emissions regulations issued by the California Air Resources Board, helped create a renewed interest in electric vehicles. The first turning point that sparked the interest we see today in electric vehicles was the introduction of the Toyota Prius in Japan in 1997. The Prius became the world's first mass-produced hybrid electric vehicle. The other event that helped reshape electric vehicles was the investment of \$115 Mn+ for 18000+ charging stations across the globe.

Countries like the USA, Norway and China, in particular, have been the flagbearers of the EV transition. They continue to lead the world in EV adoption. Some of the key initiatives taken by Norway include zero vehicle fee and VAT in the late 1990s, zero toll tax & road tax in 2001. China and the US have also shown keen interest in EV deployment. China has taken many steps, such as innovative battery technology, new business models (battery subscription) and multiple EV options. Moreover, globally the battery cost has been reduced to half from 2010-13 by investing in battery technology.

EV Penetration - Global Benchmarks  
2022

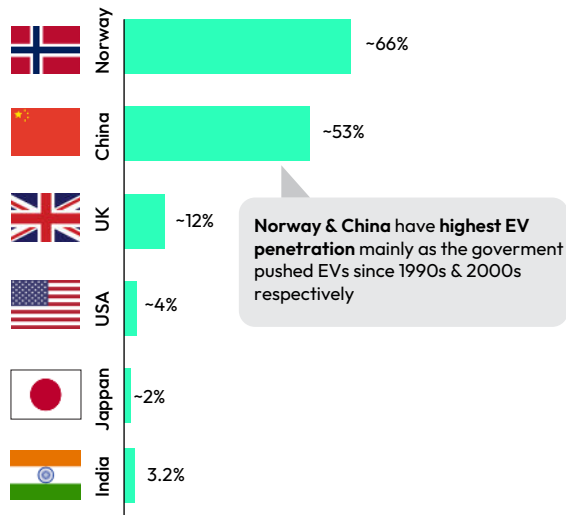

India is predominantly a 2W market and as of CY2022, its overall EV penetration including 2W is ~3.2%; other developed countries are 4W-dominated markets

Figure 1: EV Penetration - Global Benchmarks

## 1.2 India's EV Revolution with E2W as Frontrunner

**“India is the largest 2W market in the world, and it will only grow further”**

Unlike western economies primarily dominated by 4-wheelers (4Ws), 2-wheelers (2Ws) have been the preferred mode of transport for price-conscious Indians for many decades. This is because they offer ease of manoeuvring through congested roads, lower carbon emissions and higher fuel efficiency. Hence, they are an economical alternative to public transport and 3 or 4-wheelers.

Further, increasing urbanization and the need for personal mobility, coupled with increased household disposable income, more nuclear families, and increased access to credit, have turned India into the largest two-wheeler market in the world, with 375- 400Mn 2Ws on road.

Two-wheeler market in India  
Sales volume in Mn, FY 2018-2022, 2030P

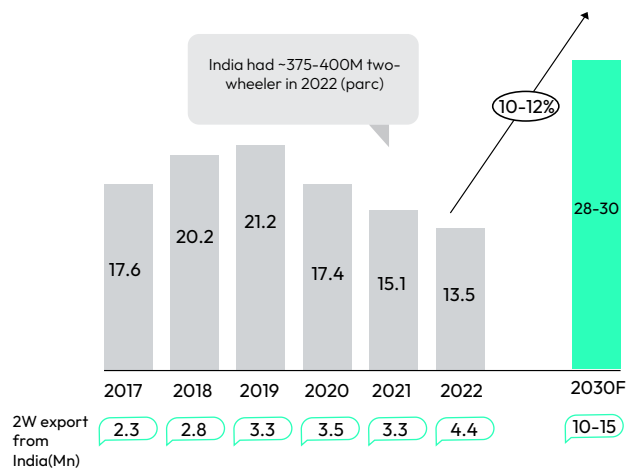

Source(s): SIAM, Redseer Analysis, Secondary Research

Figure 2: Two-Wheeler Market in India

However, affordability is key for any product or service to achieve scale in India, which is also applicable to the EV industry. Increasing petrol prices by 60% in the last five years and a higher Total Cost of Ownership (TCO) have been limiting affordability of 2W amongst households in India. This plays a huge role when choosing EV over ICE. Electric vehicles are more efficient, which, combined with the electricity cost, makes charging an electric vehicle cheaper than filling petrol or diesel for travel. This presents a massive opportunity for electric vehicle penetration in the 2W segment in India.

“E2W makes economic sense for 2W users, where the cost of ownership (TCO) is 20- 70% lower than an ICE equivalent.”

Cost of Ownership – E2W v/s ICE 2W  
INR; H1 2022

■ Acquisition Cost ■ Running /Fuel Costs ■ Maintenance & Repairs  
■ Insurance ■ Taxes ■ Salvage Value

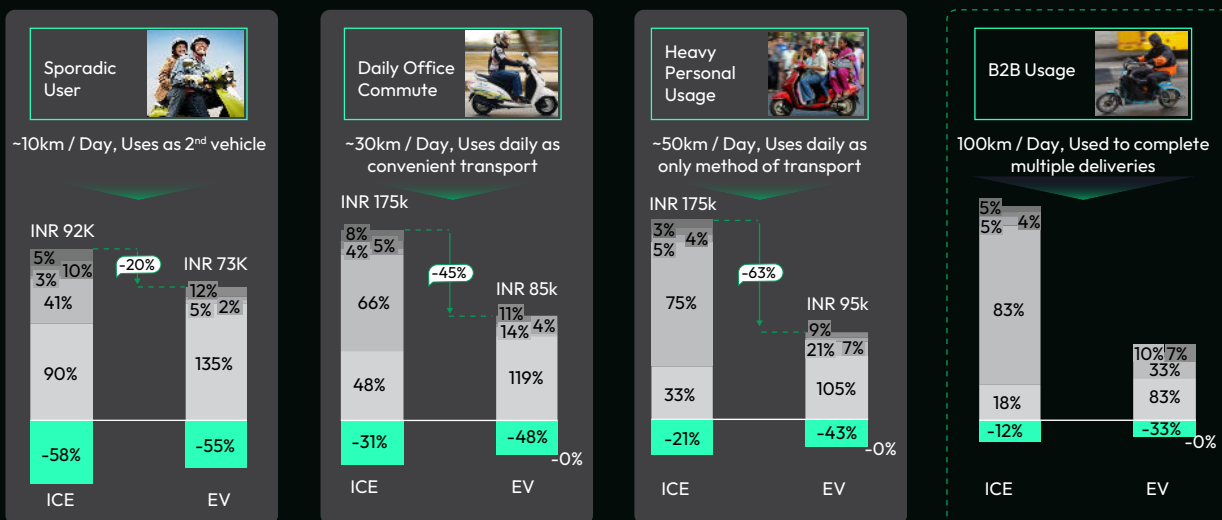

Note(s): Running cost calculation for 1500 days (5 yr), Ex-showroom prices for Ola S1& Activa 125, Insurance quotes, Servicing cost from manufacturer websites, taxes based on KA, Energy prices as of Aug, 2022

Source(s): Company websites, 3rd Party platforms, Government websites

Figure 3: Cost of Ownership – ICE 2W vs E2W

Moreover, with comparable or slightly higher initial prices, E2Ws break even quickly due to lower running costs than ICEs. It has been noted that the higher cost of electric 4-wheelers drives customers toward their less expensive ICE equivalents.

Thus, while the penetration of EVs in 4W passenger market is happening at a slower pace, E2Ws are at the forefront of the EV revolution in India. E2Ws have a more pertinent role in the Indian context. They are much more well-placed to support India's climate change goals. They can help reduce fuel import bills better than other segments.

Low cost of ownership is also attracting B2B players, such as food aggregators and last-mile delivery players, to adopt E2Ws faster. Last-mile deliveries have seen a massive uptick over the years, and the pandemic has further accelerated the dependence on doorstep delivery. And, to cater to this demand, last-mile delivery players are starting to opt for E2Ws as they make an excellent business proposition. Moreover, E2Ws hold much potential for creating a more sustainable future. Thus, these players are giving E2Ws adoption a further push.

“Before purchasing the scooter, I calculated that with my daily running, the electricity cost would be much lesser than petrol. On top of that, the service cost is also less when compared to petrol scooters”  
E2W user.



### 1.3 E2W adoption in India: A timeline

“India introduced electric vehicles in 1996; and currently has a ~1% EVs, ~4% E2Ws”

In 1996, the first electric vehicle introduced in India was a three-wheeler, invented by Scooter's India Pvt Ltd, named VIKRAM SAFA. And in 1999, Mahindra and Mahindra Ltd. launched its first electric three-wheeler. In 2001, REVA, was the 1st Indian electric car with a vehicle developed by an American company (Amerigon). While in the two-wheeler segment, Hero cycles collaborated with UK-based ULTRA Motor to launch a series of bikes in 2007; and YoByks, were also launched in the same period, as a low-speed E2W option.

Since 2010, the government has focused on EV adoption and initiated regulatory discussion & planning. This motivated companies to leverage the favourable regulatory scenario. Further, the government set up National Council for E-Mobility to encourage reliable, affordable, and efficient EVs that meet consumer performance and price expectations.

Since India was importing more auto components from China than it exports, the country realised the local auto component manufacturing ecosystem was the need of the hour. Thus, the “Faster Adoption and Manufacturing of Electric (& Hybrid) vehicles in India” (FAME-India) Scheme was launched in 2015 to promote the manufacturing and demand for electric & hybrid vehicles.

Post-FAME-I scheme announcement, the pace for startups rose. Further, in 2020, the government approved Phase II of the FAME Scheme with an outlay of Rs. 10,000 Crore to encourage E2W sales. During 2017-2021, the launch of premium high-quality vehicle gave new-age players the confidence to join the bandwagon and pushed up the E2W penetration. This led to a sudden surge in E2W adoption across India, coupled with several new product introductions.

Timeline of E2W in India

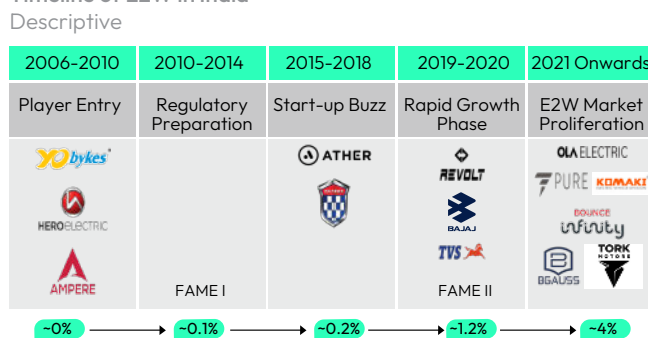

Figure 4: Timeline of E2W in India

Later in 2021, Prime Minister Narendra Modi announced that India will reduce the total projected carbon emissions by one billion tonnes till 2030, at COP26 Summit. And so, to align with this goal, India is gearing towards the electric revolution, transitioning electric vehicles into the mainstream commute vehicle of choice.

### 1.4 Indian government’s green push: Key initiatives

In India, while electrification of mobility is at a nascent stage, with overall EV penetration, at ~3.2% as of 2022, there is significant headroom for growth.

EV Penetration in India

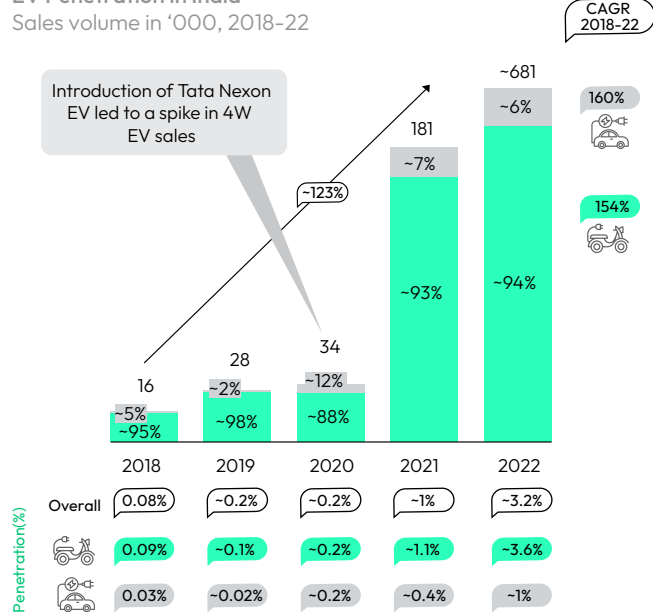

Source(s): Protocil, Reuters, Heycar, Morth, eetasia, Vahan, Redseer Analysis

Figure 5: EV Penetration in India

Thus, the Indian government has taken many proactive steps to develop the E2W ecosystem, such as subsidising vehicles for faster adoption, incentivising manufacturing and developing EV infrastructure. Around 16 states in India have also finalised comprehensive EV policies.

Regulation, consumer behaviour, and technology are important drivers of the fundamental transformation of sustainable and clean mobility. Following is a comprehensive roundup on Indian EV Policies implemented to unleash the growth of Electric Vehicles.

### Demand-centric Schemes

- ⚡ FAME II policy: The policy was introduced with outlay of INR 10,000 Crore for three years from April 1, 2019 and is applicable in all states in India. 86 per cent of the fund has been allocated for creating demand by supporting 7000 EBuses, 5 lakh E3Ws, 55000 E4W passenger cars (including strong hybrid) and 10 lakh E2Ws. It also offers a price incentive of INR 15,000 (\$~200) per KWh up to 40% of vehicle cost
- ⚡ State-subsidy on EV: 7 Indian states provide incentives in the range of INR 2,500-10,000 per KWh on EV purchase
- ⚡ Tax benefit: Government offers income tax benefit to interest paid for loan on EV
- ⚡ Waiving-off vehicle registration cost & road tax: States including Bihar, Gujarat, Madhya Pradesh, Maharashtra, Punjab and more have announced exemption of motor vehicles taxes and registration fees on electric vehicles

### Supply-centric Incentives

- ⚡ Production Linked Incentive (PLI) for advanced cell chemistry: Government has allocated incentive of INR 18,100 Cr. to setup 50 GWh cell manufacturing capacity. This will enable India to leapfrog from a traditional fossil fuel-based automobile transportation system to an EV based system
- ⚡ PLI for Advanced Automotive Tech (ATT): Government has allocated INR 25,938 Crore budgetary outlay to manufacturers on demonstrated sales and investment in ATT (including EV) to promote local development and manufacturing of E2W
- ⚡ Land concessions by various States: Andhra Pradesh and Tamil Nadu aim to develop exclusive EV parks with plug-and-play manufacturing facilities. Kerala and Bihar, too, aim to create EV manufacturing clusters with speedy land allotment, common infrastructure creation, R&D facilities, and more. Telangana and Punjab encourage the setting up of EV manufacturing in existing industrial areas

### Infrastructure Incentives

- ⚡ Incentive on setting up charging stations: Under the FAME II scheme, the government has allocated INR 1,000 Cr incentives for development of EV charging station
- ⚡ 2,877 public charging stations have been set up in 68 cities of India. 1,576 stations to be setup across 9 expressways and 16 highways. Other than these public charging station, ~3000 charging stations has been installed by private players (E.g. Ather Energy, Charzer, Statiq etc.)



## 1.5 Evolution of Market penetration

“The E2W market is well spread across India, both across Metros & Tier-4+ cities”

2W in India – Overall and E2W  
In % of total sales, FY2022

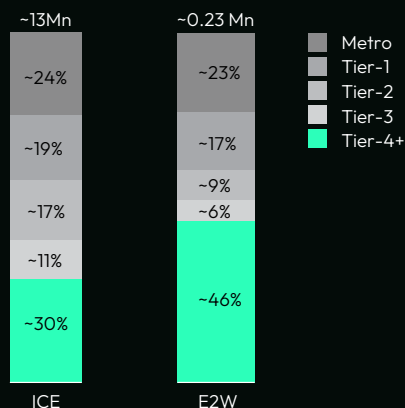

Source(s): Redseer Analysis, Secondary Research

Figure 6: 2W in India - Overall & E2W

India is the largest 2W market globally, and ICE vehicles are well spread across all tiers. Faster and early adoption of E2W in India has been observed across all tiers. Tier-4+ cities accounted for ~45% of electric sales volume in FY22. OEMs have also been investing and ramping up their focus on affordable range products to cater to the Tier-2+ market.

Mass EV adoption in the last few years has been made possible by many tipping points and demand/supply tailwinds. FAME Scheme, for instance, is a government scheme to subsidize electric vehicles and charging infra to promote early adoption of EVs. These incentives have led to lower vehicle prices with a reduction of up to 40% cost of E2W vehicles. On the supply side, the FAME scheme has promoted local sourcing and subsidized charging stations.

Value proposition such as low cost of ownership and lower maintenance of E2Ws have made perfect use cases for B2B players and has offered them better economics in their day-to-day operations. Early adopters of these are last-mile delivery players, institutions etc. This demand from B2B players has led to OEMs pushing more vehicles into the market, creating better awareness and trust.

### E2W Adoption Curve and Key tipping points

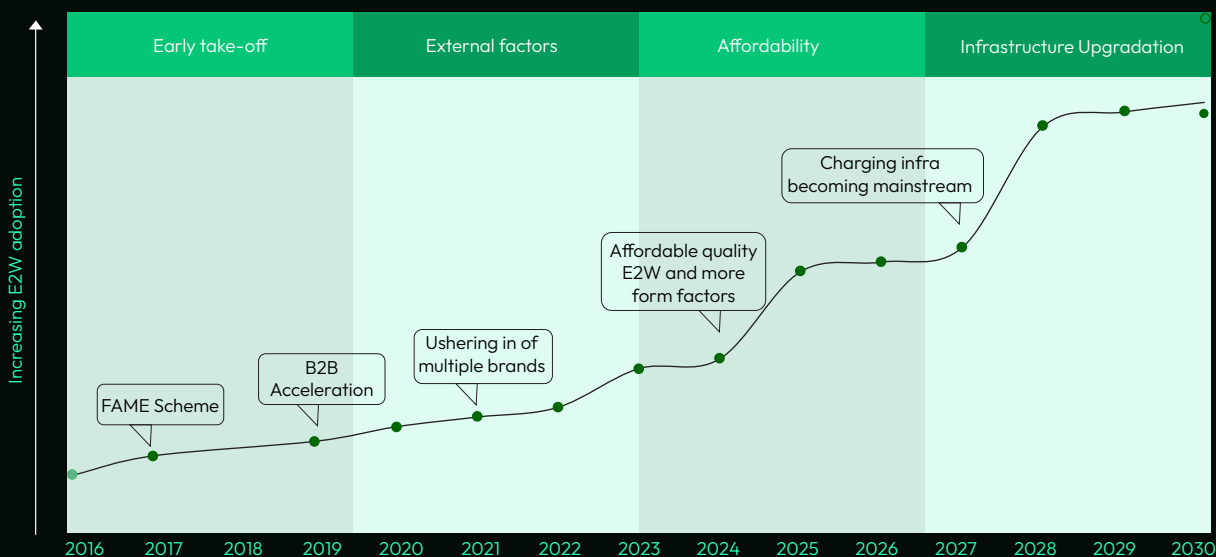

Source (s): Expert discussion, RedSeer Analysis

Figure 7: E2W Adoption Curve & Key Tipping Points

Another key driver of growth is the rise of many brands in the E2W space, such as Ather Energy, Ola Electric, Hero Electric, Bajaj, TVS, Okinawa Scooters, PUREV, and Revolt. This gave more options to consumers, pushing better adoption across price points and improving trust among the masses. As a result, we’ve seen E2W sales across India, including tier 3 and tier 4+ cities.

### Electrification of 2W in India

In % of total vehicle sold, FY2021-FY2030

Similar to ICE 2W, E2W in tier-3+ cities are expected to contribute ~50% of total E2W by 2030

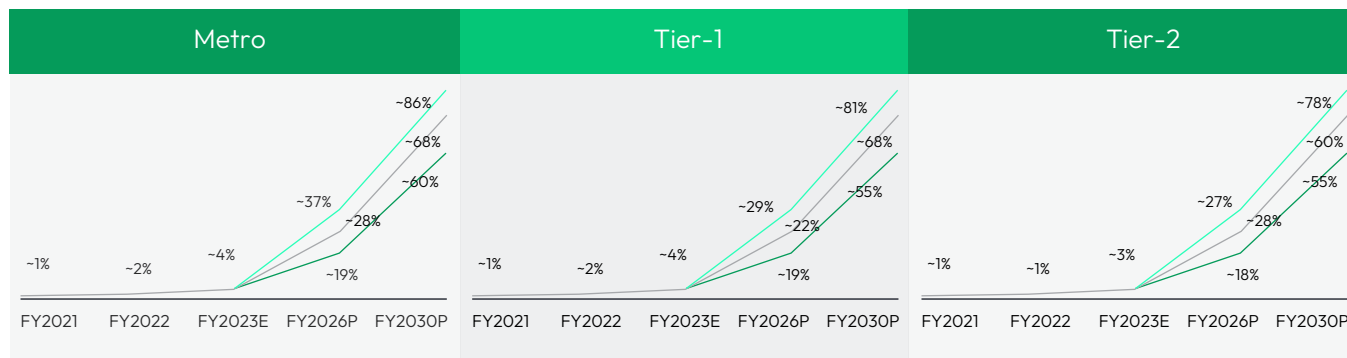
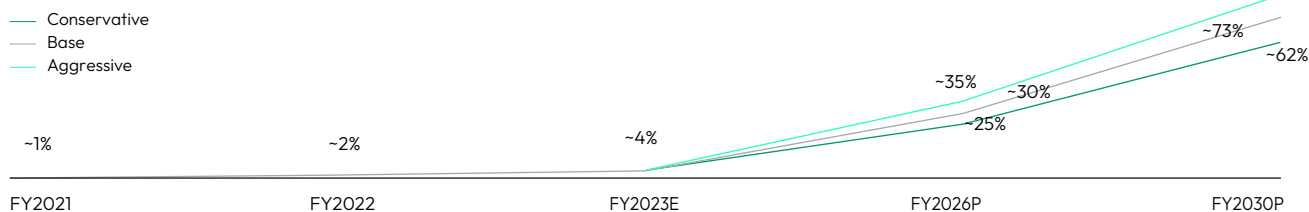

Source (s): Expert discussion, Redseer research, Redseer estimates

Figure 8: Electrification of 2W in India

Market penetration in the coming years look promising, we expect three factors to drive the favourable growth in E2W:

- 1 Increasing awareness and trust and comfort in buying E2W
- 2 Government push and efforts by traditional and new-age businesses for increasing access to high-quality vehicle at an affordable price
- 3 Ecosystem focus on charging infrastructure to resolve issues of range anxiety, making E2W vehicle of choice for inter-city commute

With above factors playing out, we expect E2W penetration to grow from 4% in FY2023 to 60-80% by 2030. Like ICE 2W, E2Ws in Tier-3+ cities is expected to contribute 50% of total E2W by 2030.

“E2W sales volume in India is expected to reach ~22 Mn by 2030”

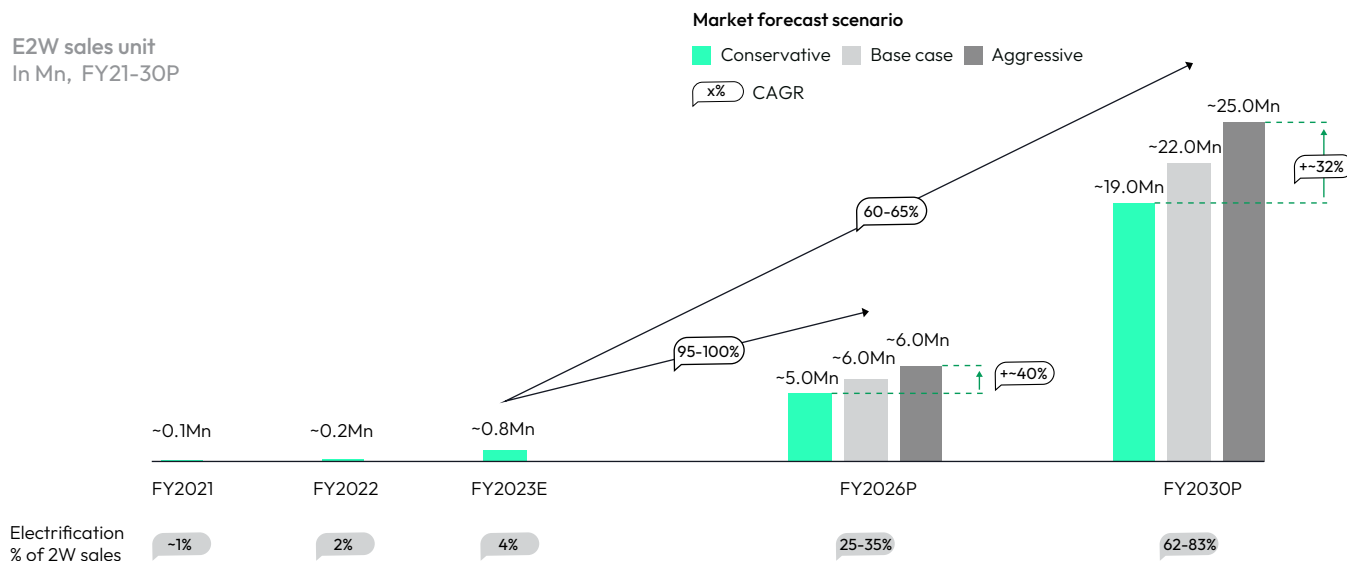

Source (s): Expert discussion, Redseer research, Redseer estimates

Figure 9: E2W Sales Unit

## 2. E2W Provides Level Playing Field for the New Entrants

### 2.1 Lots of room for everyone to grow!

“Electrification in the 2W market will amplify the slowing 2W market. As a result, the overall 2W sales in FY2030 may witness an upside of ~23% due to electrification.”

Transport is a fundamental requirement of modern life, but the traditional combustion engine is polluting. With rising fuel prices, new vehicle buyers are re-considering their purchase decision due to increased cost of vehicle ownership. As more EVs hit the road, consumers are becoming familiar with them, more so in cities and urban towns, and many of them are buying an EV.

In addition, the rise of several recognised brands in E2W space, such as Ola Electric, Ather Energy, Bajaj, and TVS, increased trust amongst buyers. It gave more options to 2W buyers, pushing better adoption across price points and improving trust among the masses. This resulted in boosting E2W sales across India, including tier 3 and tier 4+ cities. Interestingly, few E2W models are on waiting period, reflecting vehicle trust.

In mid-to long term, 2W buyer using public transport (in the absence of E2W) are also likely to buy E2W because of lesser upfront (decrease in battery prices) and running costs.

Total 2W sales volume forecast with and w/o electrification  
In Mn, FY22-30P

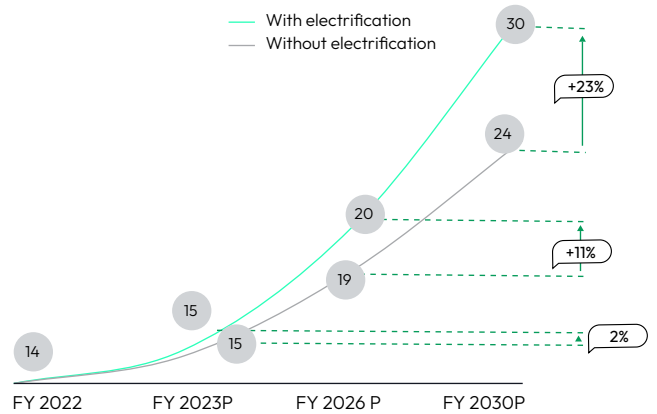

Source (s): Expert discussion, Redseer research, Redseer estimates

Figure 11: Total 2W Sales volume forecast with and without electrification

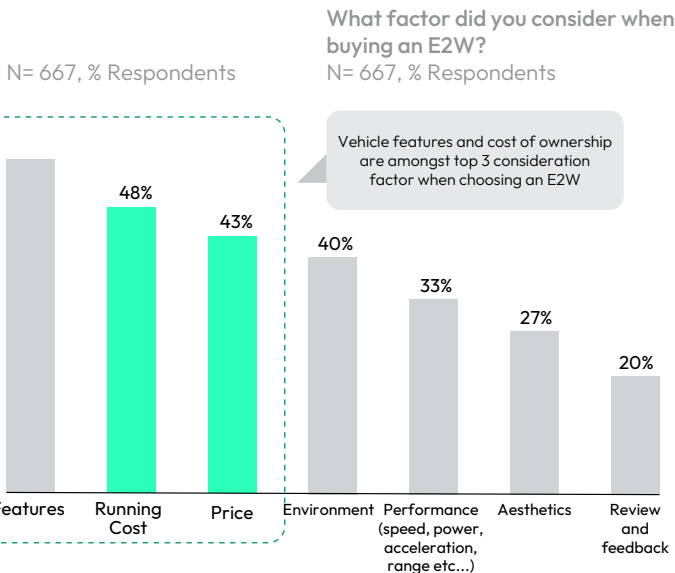

Source (S) : Consumer Surveys

Figure 10: Factors considered when buying an E2W

Electric vehicles (EVs) are becoming a strong and economical alternative that is getting haulage in the current situation where petrol and diesel prices are at an all-time high.



A robust charging infrastructure will become essential for long journeys as adoption increases. In addition, customers using E2W for all use cases, in general, would require fast charging stations. Thus, charging infrastructure companies will become fundamental drivers for adoption.



## 2.2 E2W - A level playing field

As India is embracing the e-mobility revolution and taking concrete action to electrify its transport sector, E2W provides a level playing field for the new entrants. EVs are considered the game-changers for the environment. They are, air and noise-pollution-free, and with technology at their core, their sales are experiencing rapid growth. Internal combustion engine (ICE) 2W are still the dominant market contenders. However, here are a few pointers to understanding how far E2W can travel against ICE vehicles.

### EV vs ICE: Efficiency & Control Descriptive

 Gasoline Powered ICE	 Electricity powered EV
<b>More moving parts &amp; lesser efficiency</b> <ul style="list-style-type: none"> <li>Moving parts in ICE 2W are 40+ , hence have higher friction and energy losses resulting in poor energy efficiency</li> <li>Because of more moving parts, ICE requires more maintenance</li> </ul>	<b>Lesser moving parts and higher efficiency</b> <ul style="list-style-type: none"> <li>EV moving parts are ~10+ Hence have higher energy efficiency because of lesser heat generation and friction losses</li> </ul>
<b>Higher NVH &amp; vehicular emission</b> <ul style="list-style-type: none"> <li>Because of more moving parts, NVH ( noise, vibration and harshness )in ICE is higher for a comparable speed in EV</li> <li>ICE has higher vehicular emissions requiring additional parts in the vehicle to treat exhaust gases (i.e. catalytic convertor )</li> </ul>	<b>Ability to read the data &amp; make changes OTA<sup>1</sup></b> <ul style="list-style-type: none"> <li>Ability to read the data &amp; change the algorithms across all the systems with ease</li> <li>Ability to make changes in existing running fleet OTA (over the air) without making any changes in hardware</li> </ul>

### Feature comparison of a typical ICE and EV

Features	EV	ICE	
Connectivity	App connectivity	✓	✗
	Geofencing	✓	✗
	Touch screen inter active display	✓	✗
Drive Assistance	Reverse mode	✗	✗
	Cruise control	✗	✗
	Navigation assist	✓	✗
Safety	Predictive maintenance	✗	✗
	Component failure alarm	✗	✗

- ✓ Available in most vehicles (>90%)
- ✗ Available in less than Fifty Percent vehicles
- ✗ Available in less than Ten Percent vehicles

Note(s): VCU: Vehicle Control Unit

Source(s): Redseer Research, RedSeer Analysis

Figure 12: Advantages EV has over ICE. | Feature comparison of a typical ICE and EV

From customisation and connected features to safety, EV being a technology product, offers multiple advantages such as customisation of the dashboard based on riding behaviour, geofencing & navigation to provide a way for users to connect to their vehicle, safer riding options by preventive maintenance and accident prevention through data tracking.

In addition, technology enables optimised vehicle operation through data sharing between components to control the battery power supply. It allows remote connectivity and data tracking on the cloud, allowing OEMs & users to interact with the vehicle. The relative absence of the big legacy players in the E2W segment has further fuelled the ambition and added to the lustre of the opportunity for new-age players.

### EV Manufacturing Drivers in India

Characteristics	
Low Entry Barrier	Easier Assembly Process
	Absence of Incumbents
Favourable Ecosystem Drivers	Convenient Supplier Network
	Rapidly Growing User Adoption
	Regulatory Support

Figure 13: EV Manufacturing drivers in India

Due to more straightforward process and fewer sub-components, E2W are easier to assemble. As a result, several first-time players like Okinawa, Ampere, and others introduced E2W products. Moreover, the nascency of E2W technology allows a level playing field for both established and new-age brands. For instance, ICE majors like Honda, Bajaj, Hero, and TVS do not have a significant advantage over the new-age players except in distribution.

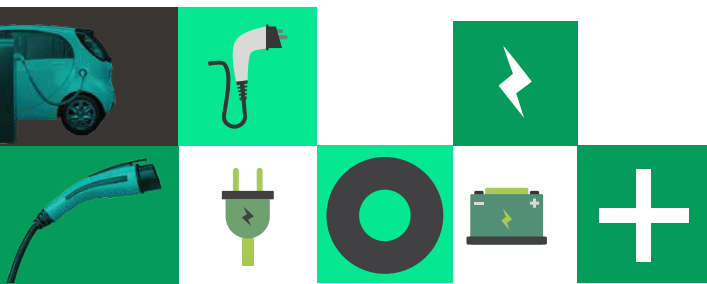

### 3. Localisation and Vertical Integration in Play

“EV Supply chain, is over-dependent on China, which critically slowed-down industries recently. Thus, OEMs would try to overcome such uncertainties by setting up local Supply Chains.”

The global EV supply chain has been mostly in the western hemisphere and East Asia; Many Indian brands primarily assemble components imported from China and South Korea. A few cases of integrated designs also offer cost savings of up to 25%. Thus, vertical integration, in-house design and localised supply chain will be mid-to long-term play in E2W. Realising the same, India is gradually shifting to manufacturing key components like battery cells.

#### 3.1 Localisation of EV supply-chain ecosystem

While the Indian Government has created momentum for EVs through its policies, several states are racing to attract investments from OEMs and components players to emerge as EV manufacturing hubs. Current levels of localization in the Indian EV sector have been limited due to the cost competitiveness of foreign providers, the deep technological expertise involved, and limited access to crucial raw materials such as lithium and other rare earth metals.

EV supply-chain ecosystem  
Descriptive

	Raw material	Component	OEM	Distribution	After Sales Service	
Major Types	<ul style="list-style-type: none"> <li>Aluminium</li> <li>Rubber</li> <li>Plastic</li> <li>PlastCopperic</li> <li>Manganese</li> <li>Graphite</li> </ul>	<ul style="list-style-type: none"> <li>Steel</li> <li>Nickel</li> <li>Cobalt</li> <li>Copper</li> </ul>	<ul style="list-style-type: none"> <li>Motor</li> <li>Chassis</li> <li>Electronics</li> <li>Platform, ACU, VCU</li> <li>Battery</li> </ul>	<ul style="list-style-type: none"> <li>Innovation led – vertically integrated player</li> <li>Assembly led player</li> </ul>	<ul style="list-style-type: none"> <li>Dealership model</li> <li>D2C</li> <li>Omni channel</li> <li>Multi brand dealership</li> </ul>	<ul style="list-style-type: none"> <li>D2C – In app support</li> <li>Service station</li> </ul>
Location	<p>DRC-Cobalt, China-Mn, Co refining, Australia-Li, Chile-Li, S. Korea-Co &amp; Li</p>			<p>Key Players in India</p>		
Key Players						

Source(s): National Renewable Energy Laboratory, U.S.A., nsenergybusiness.com

Source(s): National Renewable Energy Laboratory, U.S.A., nsenergybusiness.com

Figure 14: EV Supply Chain Ecosystem

In terms of cost, the battery is the most intensive component of an EV, while BMS and TMS (Battery / Thermal Management Systems) are the other crucial components. The other specialized parts, such as motors, controllers, and the rest of the drivetrain, contribute to the overall cost. However, to leverage India’s cost advantage and achieve the desired high levels of localization of EV manufacturing in India, there must be commitment and investments in technology from incumbent OEMs and auto component companies.

Further, the technological advantage of E2Ws empowers its manufacturing and R&D to best leverage 'Industry 4.0' and connected manufacturing. By leveraging Internet-of-Things (IoT), cloud computing and other such technologies, today's manufacturers integrate various stages of production digitally. Further, depending on data consumption, Industry 4.0 can improve demand forecasting, manufacturing processes, product features, and operations. In India, these use cases are already being deployed in the sector. Connected features of E2Ws have enabled OEMs to completely integrate all departments with real-time usage and thus offer high success to Industry 4.0-ready players.

## 3.2 Brands leading the way for EVs in India

E2W Brands in India  
Alphabetical, Non-exhaustive



Source(s): Vahan Website

Figure 15: E2W Brands in India

India's E2W market has 150+ brands, majority of them being assemblers. As focus on electrification of 2W increases, India is gradually shifting to robust domestic manufacturing of critical components such as cells, battery packs, motors and VCUs. For instance, Ola Electric, Exide, and Reliance have set up/are setting up their cell R&D and manufacturing, and Ather Energy has employed in-house battery manufacturing. Other OEMs have also been sourcing batteries from Sun Mobility, and Exide, among others. Moreover, many players have opted for custom-designed motors from players like Bosch and tech-oriented companies with high-quality products like Ather Energy, Ola Electric & TVS are designing and coding their VCU in-house. There is an increased awareness of how in-house design or manufacturing of vital strategic components can lead to IP protection and quality consistency. Integrated designs can also lead to cost savings of up to 25 %.

## 3.3 Verticalization of E2W manufacturing in India

E2W as a product is fundamentally different from traditional 2Ws, with much more advanced components and technology. Many components used in E2W, are even new to the 2W industry and require establishment of separate production facilities. To cater to this need-gap many new OEM - supplier engagement models have emerged which require a higher degree of collaboration.

OEMs have adopted diverse component sourcing strategies with increased focus on quality parameters, such as technology strength, R&D capabilities, development and design validation, lifetime ownership of component performance, level of value chain integration, etc.,

R&D, Technology prowess vs. manufacturing prowess in India E2W market  
By E2W OEMs in India

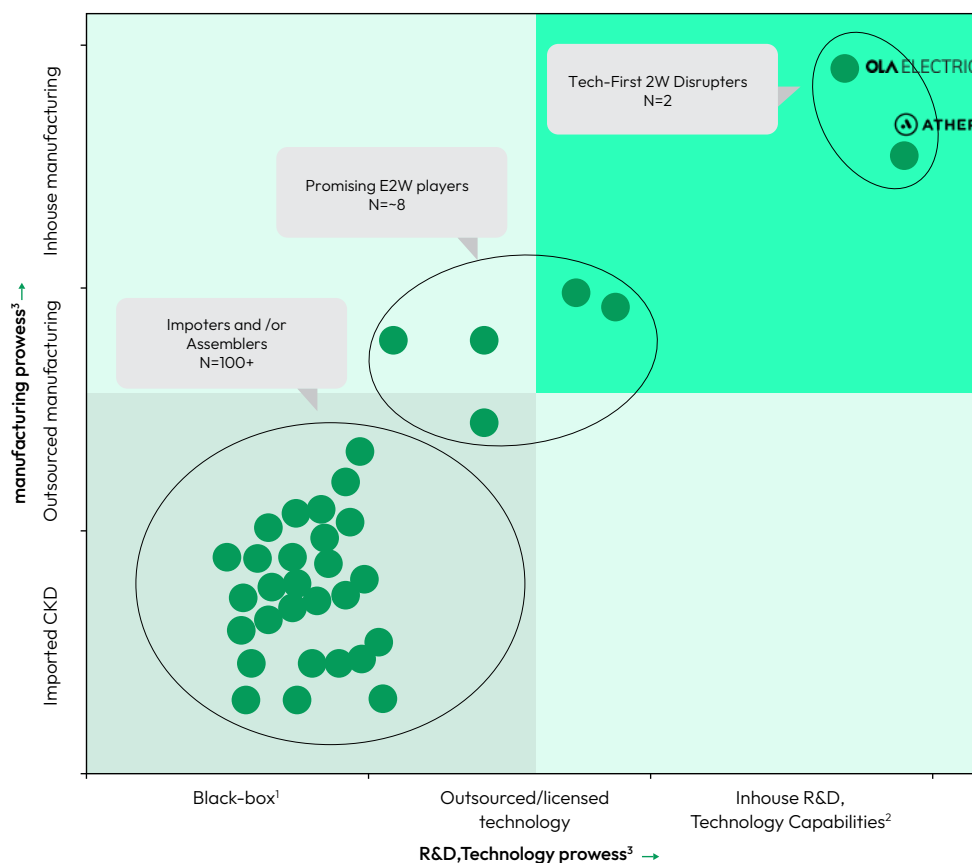

Note(s): 1. Black-box refers to OEMs importing/ domestic outsourcing CKD kits without a clear view of the R&D and technology stories behind components/software/firmware  
2. In-house R&D, Technology Capability refers to most of the product development (hardware/software) and R&D for critical components is done in-house with full control on optimization for vehicle performance and quality  
3. Placement on the axes is qualitative

Source (s): Expert discussion, RedSeer Analysis

Figure 16: E2W Brand Perceptual Map - Manufacturing & Technological Prowess

Regarding the solution approach, system integrators will increasingly play a key role in supplying to OEMs. Solutions<sup>1</sup> such as ‘battery, BMS, thermal management, PDU- connectors’, ‘motor controller, transmission-converters, control units’, etc., will come to the fore. Component suppliers with a system-based approach & a strong hold over technology development can ensure business consistency.

Over time, three cohorts have emerged for India’s E2W players. These include “Importer-Assemblers”, “Promising E2W players” and “Tech-first disruptors”.

Today we have more than 100 importers and/or assemblers. These are OEMs importing/ domestic outsourcing CKD kits without the full view of the R&D and technology stories behind components or software or firmware. Next, we have a few promising E2W players with varying degrees of in-house, outsourced or licensed technology and manufacturing strategies.

Finally, we have two players, OLA Electric and Ather Energy, with highest in-house R&D and technology capabilities. These players have most of the product development (hardware/software) and R&D for critical components in-house with complete control for vehicle performance and quality.

Currently, E2W component engineering and R&D have two types of components<sup>1</sup>, including core E2W components such as battery pack, cell, BMS, vehicle control unit, electric motor, fast charger, and differentiators such as vehicle OS, big data and analytics.

Core E2W components are new in technology and require R&D for high-quality and high-performance vehicles. But connected and smart features will provide a seamless vehicle usage experience.

Overall, while a low level of technology prowess leads to sub-standard vehicle performance, unsafe vehicles and inconsistent customer experience, high level of technology prowess leads to better vehicle performance, control on the quality of the vehicle and customer experience.

<sup>1</sup>Notes on Components

E2W component engineering and R&D

Spectrum across components



Note (s):

1. Placement for component "R&D and engineering" on the spectrum is qualitative
2. Color gradient in the spectrum refers to the control on component quality: "Green refers to full-control", "red refers to "No control"
3. Currently there is no in-house R&D and design of cell happening in India. However, companies like Ola Electric, Reliance have announced plans
4. Black-box refers to unknown capabilities of R&D and design element of BMS

Source (s): Expert discussion, RedSeer Analysis

Battery is the most sensitive & expensive EV component. It impacts key adoption factors such as range, safety, charge time & cost. So, rising EV demand will correspondingly drive the need for batteries.

Battery Management System(BMS) monitors the battery pack's state of charge & health. It protects against faults, optimizes charging & discharging, and monitors the rate of use. It also undertakes cell balancing, preventing only a few cells from getting stressed.

Thermal Management regulates the battery pack to operate in the desired temperature range for optimum performance and life.

Housing forms the outer casing of the battery that holds the module assembly together and ensures battery protection. Furthermore, the Connector is the electro-mechanical part that interfaces the battery to electronic devices.

## 4. Supply-Side Challenges in EV Adoption

EV adoption in India is expected to rapidly grow as the government takes various initiatives to overcome obstacles observed in the industry such as complex manufacturing set-up, high infrastructure costs and other such supply-side restrictions.

The various initiatives by the government include announcements and notifications around delinking batteries from EVs during the sale, incentive schemes (FAME II and PLI) linked to advanced batteries, increased import duty on cells and battery pack.

Another major obstacle faced by the industry revolves around the evolution of EV technology. Technological challenges are also being overcome as research & development progresses.

### 4.1 Battery pack, a critical part of vehicle powertrain

Cell technology is still nascent, and technology companies worldwide are working towards reducing raw material costs and improving efficiencies. Lithium is the most popular electrode element in an EV battery, with most OEM players opting for Nickel Manganese Cobalt (NMC).

Comparison of EV Battery types  
Descriptive

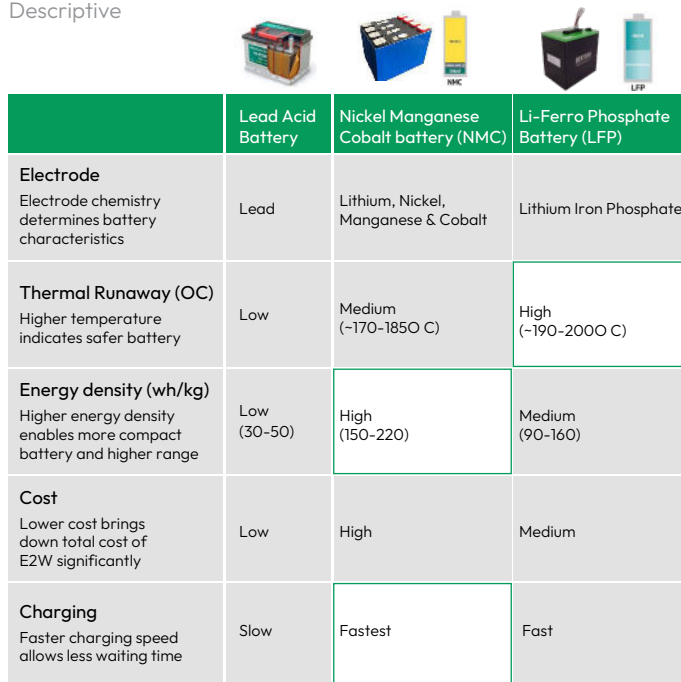

	Lead Acid Battery	Nickel Manganese Cobalt battery (NMC)	Li-Ferro Phosphate Battery (LFP)
<b>Electrode</b> Electrode chemistry determines battery characteristics	Lead	Lithium, Nickel, Manganese & Cobalt	Lithium Iron Phosphate
<b>Thermal Runaway (OC)</b> Higher temperature indicates safer battery	Low	Medium (~170-185O C)	High (~190-200O C)
<b>Energy density (wh/kg)</b> Higher energy density enables more compact battery and higher range	Low (30-50)	High (150-220)	Medium (90-160)
<b>Cost</b> Lower cost brings down total cost of E2W significantly	Low	High	Medium
<b>Charging</b> Faster charging speed allows less waiting time	Slow	Fastest	Fast

Note(s): # of SKU models offered in the market

Source(s): Redseer research

Figure 17: Battery Variety Comparison

At 77%, currently, NMC is the most used electrode element for E2W batteries. LFP has a usage share of 23%. It is an alternate element that offers good performance and can have more share subsequently due to lower costs and good performance. Lead acid batteries are unsafe and provide poor performance; hence, have been phased out of the market.

A significant barrier to EV adoption is the battery manufacturing process and supply chain optimization. To enable EVs, new mining and supply networks are required. The lithium-ion battery is the most common and frequently utilized EV energy source. However, India does not manufacture lithium-ion cells or their raw materials. The country relies on imports for EV batteries, resulting in exorbitant prices for these vital components and, eventually, EVs. This is also a key reason for the price difference between ICE and EV vehicles.

Size, weight, and compactness are critical performance metrics for an EV battery. A lighter battery allows for a larger capacity battery to be fitted in the vehicle, which enables an extended driving range. Longer ranges are crucial in reducing the “range anxiety” of current owners.

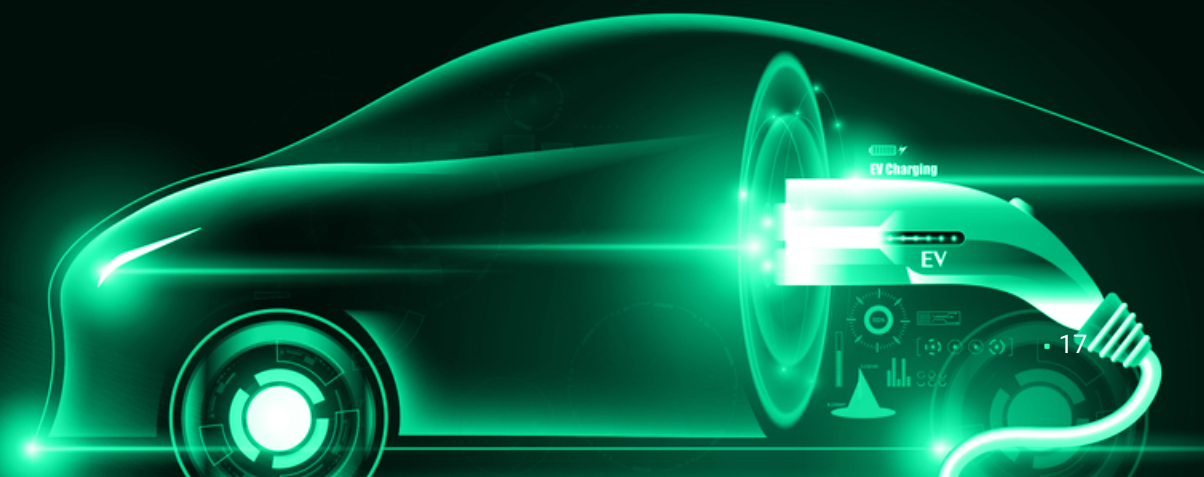

Li-Ion battery technology across globe  
Descriptive

More than 90% of Li-ion battery supply and technology is controlled by China, Japan & South Korea

	China	Japan	South Korea
Global Market share	35-40%	~20%	35-40%
Key Riding Characteristics	Road infrastructure: • 40% of China's roads are highways	Road infrastructure: • 80% of roads are paved • Govt. track & follow preventive repairs for roads	• Dry & freezing temp. during winters • Humid & hot during summer (not as extreme as Indian summers)
Major Players			

Reason for different battery tech. requirement for India

**Tropical climatic conditions**

**High temperature & humidity**  
Extreme high temperature (as high as ~50° C), heavy rains and humidity (as high as 95%+) makes it a requirement for cell to sustain & operate efficiently in such conditions

**Poor road infrastructure**

- 30% of villages have no access to all-weather roads
- 40% of Indian roads are dirt roads

Hence the cell chemistry, battery technology and the whole vehicle need to be redesigned to sustain those riding conditions

Source(s): Redseer Analysis, Imarc  
Figure 17: Battery Variety Comparison

Most EV technology (battery cell, BMS etc.) has been West- and/or China-focused, which is seldom suitable for India and SEA. Until 2020, India was dependant on China or Taiwan for lithium-ion (Li-ion) cells.

Indigenization is required in cell manufacturing because:

- ⚡ India has a very different climate than the countries from where it imports cells, eventually Indian OEMs and other stakeholders would work on developing cell technology which is made for Indian needs and use case.
- ⚡ The road and public infrastructure is much different than developed countries, and hence India has different requirements for battery output and charging facility
- ⚡ Dependence on foreign countries for the most crucial element for manufacturing EV batteries put India at geopolitical supply chain risk
- ⚡ ~50% BOM cost savings are expected from localized cell manufacturing

Cost competitiveness against China Li-ion batteries is a major deterrent for battery manufacturing in India. Given the uncertainty around the exact scale of EV adoption in India, large-scale indigenization of batteries is expected to take more time, especially for larger batteries.

Domestic assembly of Modules & battery packs has gained traction due to:

- ⚡ Government regulation under FAME subsidy, requiring OEMs to procure or assemble batteries domestically.
- ⚡ Indian EV OEMs prefer local assembly of their battery module and assembly packs for greater control on design, supply chain & production of India-first EV models
- ⚡ Unique Battery/Pack designs which Indian OEMs develop for best performance in Indian conditions further encourage local assembly/manufacturing.

Additionally, several players in India are working towards developing cell manufacturing capabilities in India, such as a partnership with academia, building world-class R&D capability, inviting Foreign Direct Investments (FDIs), strategic partnerships with start-ups, and supporting local companies.



## 4.2 Motor, Chassis, Mechanical Components, and others

From a manufacturing and cost perspective, other components of an EV are commoditized and mature. The list of other components of an EV include parts like

- ⚡ **Electric Motor:** Performs the core functions of the EV and translates the electric energy to mechanical motion. Electric Motor & its related technology has existed for decades; however, it needs to be optimized for power delivery and to reduce energy loss during vehicle operation. It accounts for 15-20% of the vehicle cost.
- ⚡ **Vehicle Chassis & Mechanical Components:** This includes the core structure of the vehicles and various mechanical parts like frame, body pane, and wheel. The chassis & mechanical parts account for another 25-30% of the cost. Most EV manufacturers outsource these. However, a few companies manufacture it in-house based on scale.
- ⚡ **Electronics, Electricals & Others:** Include parts like lights, screens, etc. and others account for 10-15% of the cost of EV. Most Indian EV OEMs outsource these components domestically from the core industry experts.

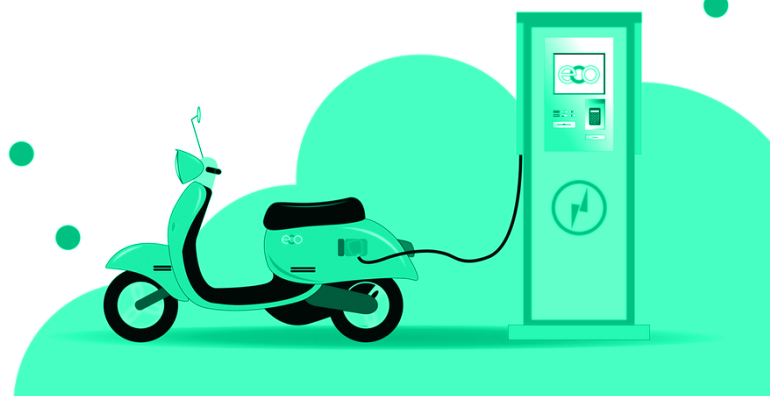

- ⚡ **Regulation:** BMS ensures that SoC (State-of-Charge) is maintained between the minimum and maximum charge limits and performs cell balancing by draining excess energy from overcharged cells. BMS relays battery parameters data to MCU, performs thermal regulation and controls the charging of the battery pack
- ⚡ **Communication:** BMS measures SoC (available charge) & SoH (State-of-Health) (condition as compared to original capacity) and delivers the info to the end user through GUI
- ⚡ **Action:** BMS regulates the power delivered through the motor by relaying current battery parameters to Motor Controller Unit. It controls the charge going in (while external charging) and out (to the motor) of the battery and the thermal management systems of the vehicle.

## 4.3 Battery management system & safety

One of the most crucial components of an EV is a deeply integrated Battery Management System (BMS). It practically controls the power delivery and other aspects of the EV and is also responsible to ensure seamless charging and discharging of the battery, its performance, and its overall functions.

BMS involves four significant processes as mentioned below.

- ⚡ **Sensing:** BMS continuously monitors parameters such as temperature, voltage and current in and out of the battery pack to ensure safe operating conditions.

What is Battery Management System – Process Flow Descriptive

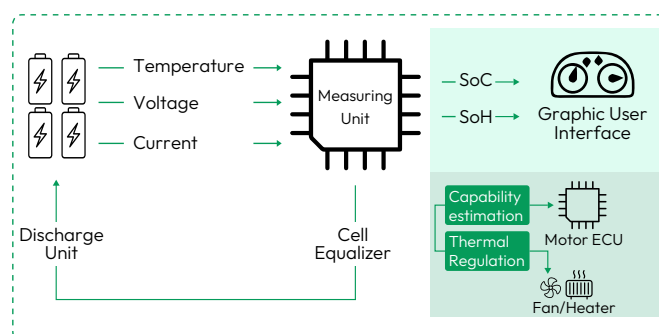

Source(s): Redseer research

Figure 19: BMS System Process visualised

### 4.3.2 Safety of Electric Vehicles

“New-age modern players with a vision of a connected product & manufacturing process are getting better prepared to provide safer vehicles in the future.”



The safety of EVs has recently gained significant media attention. Series of fires in green two-wheelers have raised concerns about the regulation and safety standards of this fast-growing section of the automobile industry. Accidents involving electric vehicles have an enormous impact on consumer perceptions of, and buzz around, EV technology, keeping trust levels low.

Fire is the most infamous safety hazard in EV, at present. There have been a total of around 21 E2W fire incidents from September 2021 – June 2022, and most of them (>50%) have been due to external factors such as short circuits in the charging grid, fluctuations in the current delivery etc. and not any fault in the product or battery. The second most common reason has been a faulty cell in the battery, which malfunctions and results in an EV fire. This too is often because of a faulty BMS or improper usage/charging of the vehicle.

Key factors listed by ICE users for not adopting EVs  
N= 242, % Respondents

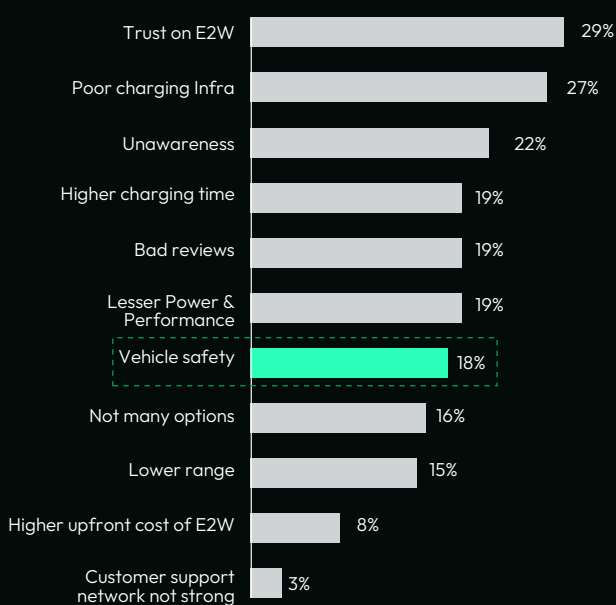

Top 3 most important factors for making purchase decision  
% respondents, N=667

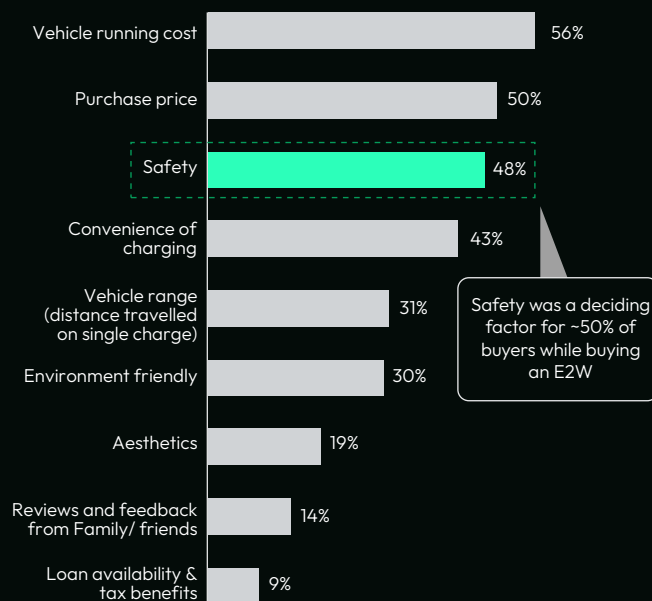

Source(s): Redseer consumer survey, Redseer analysis

Figure 20: Reasons for not adopting EVs vs Reasons for making purchase decisions

Electric vehicles may be the future of mobility in India but the race to be the first seems to be taking a heavy toll on buyers with fire incidents reported in different states of the country. Several measures are required to prevent fire accidents, such as;

- ⚡ Better Cell Chemistry: Extensive background checks for the supplier of cells. The chemistry of cells and fuse used needs to be verified
- ⚡ In-house production of Battery Cells: Many OES and OEM players have plans of setting up their own cell production facilities which will ensure better quality and lead to fewer battery cells malfunctioning later on in the EV product life cycle.
- ⚡ Stringent Modern Manufacturing Processes: Stringent quality checks during and post-manufacturing for battery assembly and thermal management system

⚡ Improved Battery-BMS Synchronization: The battery and BMS must be in sync to optimize for Indian climate, infrastructure, and usage

⚡ Better charging Infrastructure: Charging infrastructure being set up for E2W should be compliant with the product and ensure minimal fluctuations

Overall, safety is playing an increasingly important role in the EV adoption. As the demand for such safety features intensifies, the verticalization of these technologies and related manufacturing processes is also expected to grow. This shall motivate the brands to focus on better technology and stringent quality control; which eventually would benefit the overall industry.

## 4.4 Charging Infrastructure - A must for mainstreaming EVs

“Charging infrastructure in India remains heavily underpenetrated”

Average Kms travelled per day?

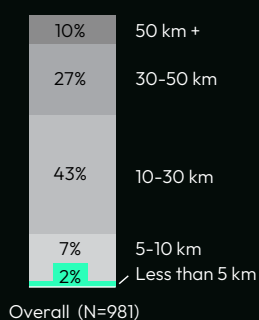

Primary purpose of buying a 2W?

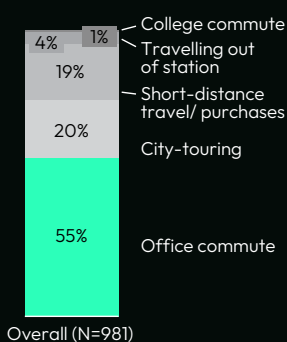

Is the E2W you purchased, the only vehicle that you own?

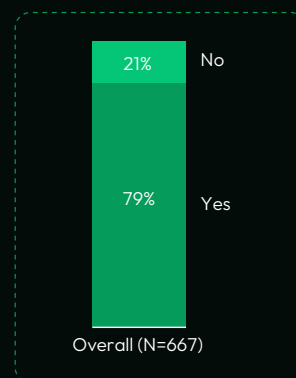

Source(s): Redseer consumer survey

Figure 21: Survey Analysis on E2W adoptability & viability for Indian market

Many 2W buyers are becoming comfortable purchasing E2W, leading to ~80% of E2W owners having EV as their first/only vehicle. Although, significant barriers to the adoption of EV Vehicles still exist such as; inadequate accessibility to EV Charging stations, slow charging and “range-anxiety.”

Most individuals have "range anxiety" because they fear an EV's capacity is insufficient to get them to their destination, despite the E2W range available being more than enough.

The range offered by most E2W brands in India is higher than the average distance travelled per day today, which is 25km, with 90% of users traveling less than 50km/day. It is also a well-placed use case for E2W given its capacity to supply increased range at low to mid-speed and quick pickup, with office commute and city sightseeing being 2W's key uses.

**Top 3 challenges you faced while using the E2W?**  
N=667, % respondents, Overall

Rank 1 Rank 1 Rank 1

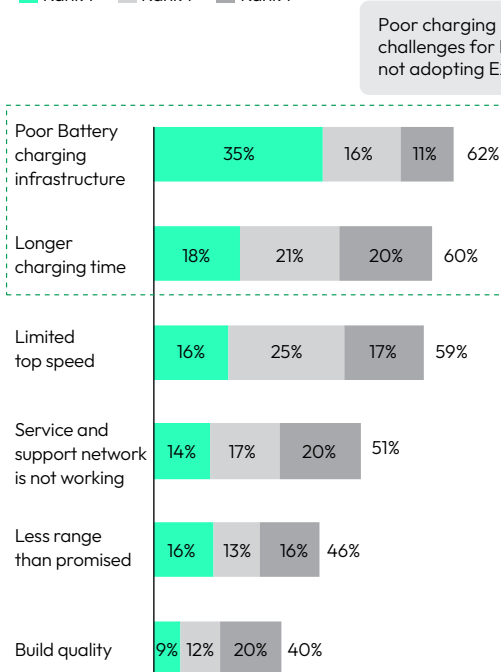

Poor charging infrastructure and slow charging are top challenges for E2W users, these factors are also deterrents for not adopting E2W

**Why did you not consider buying E2W?**  
N= 242, % Respondents

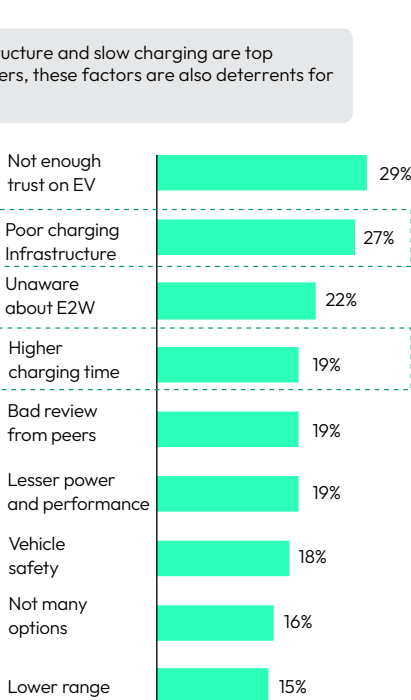

**What would be the key drivers for you to choose E2W in coming future?**  
N= 315, In %

Recent ICE 2W buyers indicated, they would buy E2W next time if more charging stations and fast charging are ubiquitous

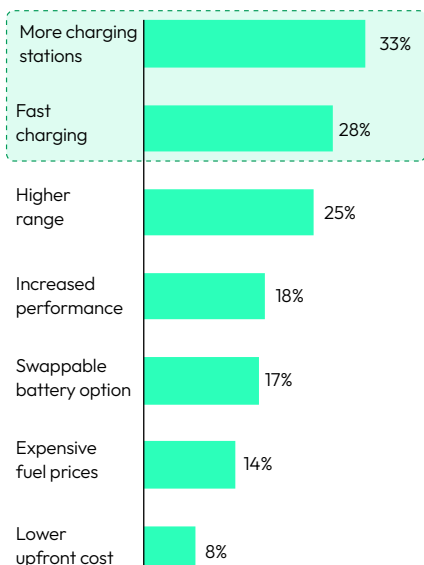

Source(s): RedSeer Analysis, Consumer Surveys

Figure 22 : Survey Analysis on E2W Adoptability

Overall, the Indian E2W sector faces various challenges with respect to charging, such as;

- 1 Difficulty setting up a fixed charging system in rented apartments: With ~30% of urban households staying in rented apartments, the uncertainty of stay duration and requirement of permission from the landlord makes it challenging to put extra capital into setting fixed charging points.
- 2 No designated parking space: Many households have no specific parking space within or close to their homes. This makes it impossible for instalment of a fixed charger.
- 3 High battery weight: With a battery weight being more than 5-7 kg, it isn't easy to carry by stairs for home charging.
- 4 Low trust in swapped batteries: E2W performance is hugely dependent on battery & BMS. Hence, currently, users have less faith in the health and quality of the swapped battery whose history is not completely known to them

Globally, accelerated EV adoption has been achieved with a robust charging infrastructure. However, currently charging station penetration in India remains very low at ten stations per '000 EVs. Charging stations will therefore be a key enabler for accelerated EV adoption and solve customers' range anxiety.

In India, the issue of charging infrastructure is being addressed by Oil Marketing Companies (OMCs), government bodies and new-age businesses. For the B2B, emerging models like Battery swapping (Battery as a Service model) are becoming ideal. On the supply side, brands are offering several mechanisms of E2W charging and chargers with their own proprietary technology.

**Public EV Charging Stations<sup>1</sup> in India**  
# charging stations, 2018- April 2022

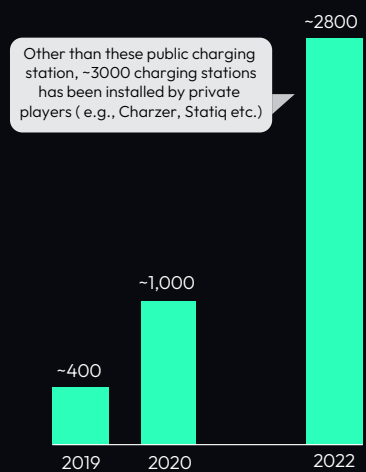

**EV Charging Stations- Global**  
# charging stations, '000s

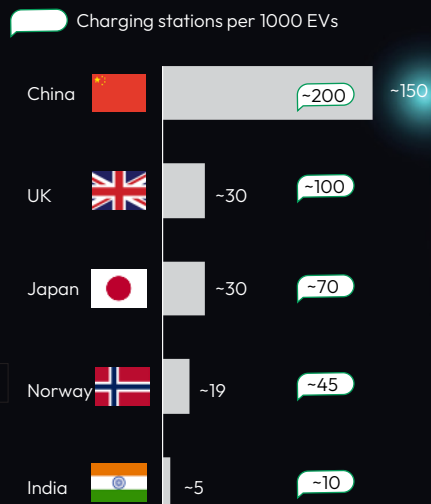

Note(s): Charging Station: A charging point that supplies electrical power for charging plug-in electric vehicles

Source(s): Vahan database, NOBIL, OFV Norway, SMMT UK, Zap-Map, BloombergNEF, EVICPA

Figure 23: Public EV Charging Stations in India & Global

Further, to solve for range anxiety and underpenetrated charging infra, the ecosystem is proactively investing in technology and innovation in addition to govt introduced mandates, and friendly policies.

Interoperability is crucial in scaling up the charging infrastructure. Thus, the government is drafting a Battery Swapping Policy to promote interoperability. Private players such as Bounce & Crayon are experimenting with interoperable models as well. However, constraints on innovation and design freedom are preventing widespread acceptance of battery standardization.

Within fixed battery system, charger standardization is expected to leverage the growing charging infrastructure and, players like Ather Energy have started taking initiative by offering their charging grids for 3rd party use free of charge.

Charging infrastructure efforts, executed and announced, by different players:

**⚡ Ather Energy:** 1000+ active chargers across 70+ cities with charging speeds of 1.5 Km/min, enabling other E2W users to charge their EV through 5A charger.

**⚡ Ola Electric:** Announcement of 100K+ Hyper-chargers in 5 years, providing E2W a range of 50 Kms in 15 mins and the target of superfast charging (0 to 100% in 5 mins) in collaboration with StoreDot.

**⚡ Hero Electric:** Announced collaboration with BOLT to set up 50K charging stations by 2023. Also announced collaboration with ElectricPe to set up 1 lakh charging points

The foundation for an EV Ready India, does rely on building the charging capacity across India, through collaboration among the stakeholders; and many private players are keen on timely and efficient implementation of EV infrastructure too; but they would require frequent encouragements from the government to ensure the successful implementation. The adoption and usage of EVs in India will surely be boosted by a robust charging infrastructure in India.

# 5. Making EVs Financially Viable

“India 2W market is driven by mass segment (price < INR 70k), and economic benefits are very critical for a product’s success in the country”

2W sales by cohort (city-tier x vehicle price point) - FY2022  
In Mn, by %

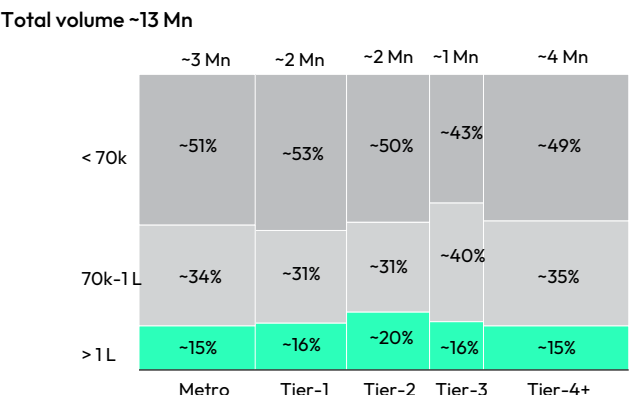

E2W sales by cohort (city-tier x vehicle price point) - FY2022  
In Mn, by %

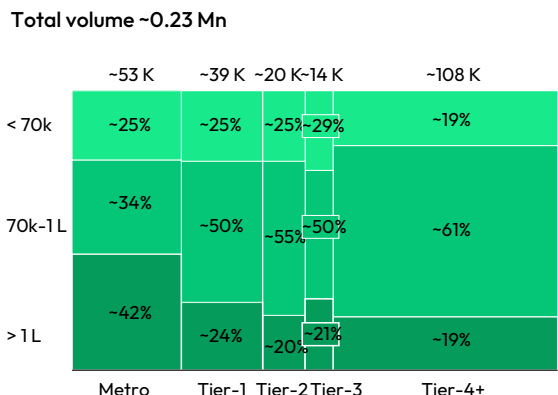

Note (s):  
 1. Sales volume by cohort (city-type x price point of vehicle) is broad estimate and represent purchase location (mostly cities) and not necessarily the place of residence  
 2. E2W vehicle refers to vehicles registered in India (vehicle which has more than 25 kmph top speed)  
 3. Metro refers to Delhi, Mumbai, Kolkata, Chennai, Bengaluru, Hyderabad, Ahmedabad & Lucknow, Tier-1: Population >10L, Tier-2: Population 5-10 Lakhs, Tier-3: Population 3-5 Lakhs, Tier-4+: Population <3 Lakhs

Source (s): Desk research, Redseer estimates

Figure 24: 2W & E2W Sales by Cohort

India's 2W market is driven by the mass (price < INR 70k) vehicle segment, which accounts for more than 50% of the market. In ICE 2W, ~50% of total vehicles sold are less than INR 70K, whereas, for EV, it is ~25%. Hence, more products are required under <70K to penetrate the segment looking for affordable vehicles to cater to the mass segment.

Presently, the E2W price is heavily subsidized, with 30-50% of the final price being supported by various central and/or state policies. Schemes like FAME, and other state-level subsidies help the end consumer to purchase the currently high-priced technology of E2W. Although, as adoption grows and brands also acquire greater economies-of-scale & -scope, these prices are likely to come down. Along with the growth in the willingness to pay for E2Ws amongst end users, which shall ensure the sustained growth of E2Ws in the Indian market.

### E2W Unit economics

In % of ex-showroom cost - Indicative only

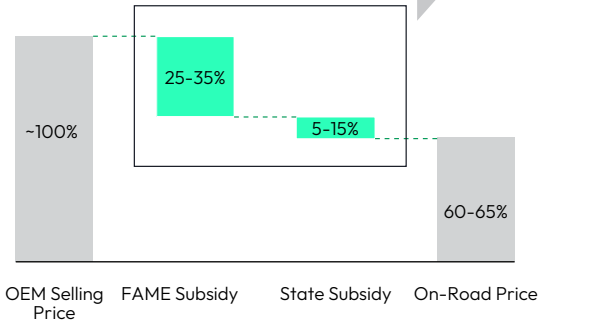

## 5.1 Initiatives towards Affordability

To encourage the use of electric vehicles in India, the government has introduced several initiatives, such as:

- ⚡ Tax exemption of up to INR 1,50,000 is available, under Section 80EEB; when paying an EV loan
- ⚡ Road Tax Exemption: Most Indian states exempt EVs from road taxes, as part of their EV policy.
- ⚡ Central and state government subsidies are available on E2Ws for up to INR 86,000
- ⚡ Supply side financial assistances such as FAME & PLI schemes also aid in lowering the end price for the customers

Additionally, E2W brands are partnering with banks and NBFCs for vehicle financing. Leading private and public banks offer loans, often at special lending rates (~20 bps lower than ICE Vehicles). Fintech players are also co-lending with banks to offer innovative schemes and attractive interest rate. With the higher incorporation of technology and traceability of the vehicle, the financiers realize the higher residual value of EVs compared to ICE vehicles. This motivates them to offer preferential funding and thereby improving the overall affordability of EVs amongst end users.

These demand-side policies have led to a significant reduction in the cost of vehicles, driving affordability and in turn the adoption of E2Ws in India. Despite these undertakings, there remain few challenges for E2W financing such as a lack of trust in new non-traditional OEMs and E2W because of its nascentcy, lack of demand due to low public awareness about electric vehicles & government schemes, and reselling concerns due to a lack of knowledge. As awareness grows, these shall be overcome and create a mainstream financing channel for EVs, just like conventional ICE vehicles.

## 6. Omni Channel Play Imminent

Until now, 2W retailing has been mostly offline-first, from booking test-drive and purchase to new vehicle delivery. But efforts are being made to implement hybrid and online modes of purchase for E2W, with an increased focus on providing a digital experience across the purchase journey. E2W retail in India is being done by majorly three channels:

- ⚡ Traditional offline channel - dealership,
- ⚡ Online D2C channels
- ⚡ E-commerce marketplaces.

Some brands have adopted a conservative approach wherein they take new vehicle bookings at both offline dealerships and online app/websites.

To sum up, omni-channel approach with experience centres and D2C collectively can today manage the complete customer journey including test rides, purchases & servicing.

### Aided by Shift in Online Consumer Maturity

What were your top 3 most important factors for making a purchase decision? – E2W  
% respondents, Local dealership N= 536; Online booking N=124

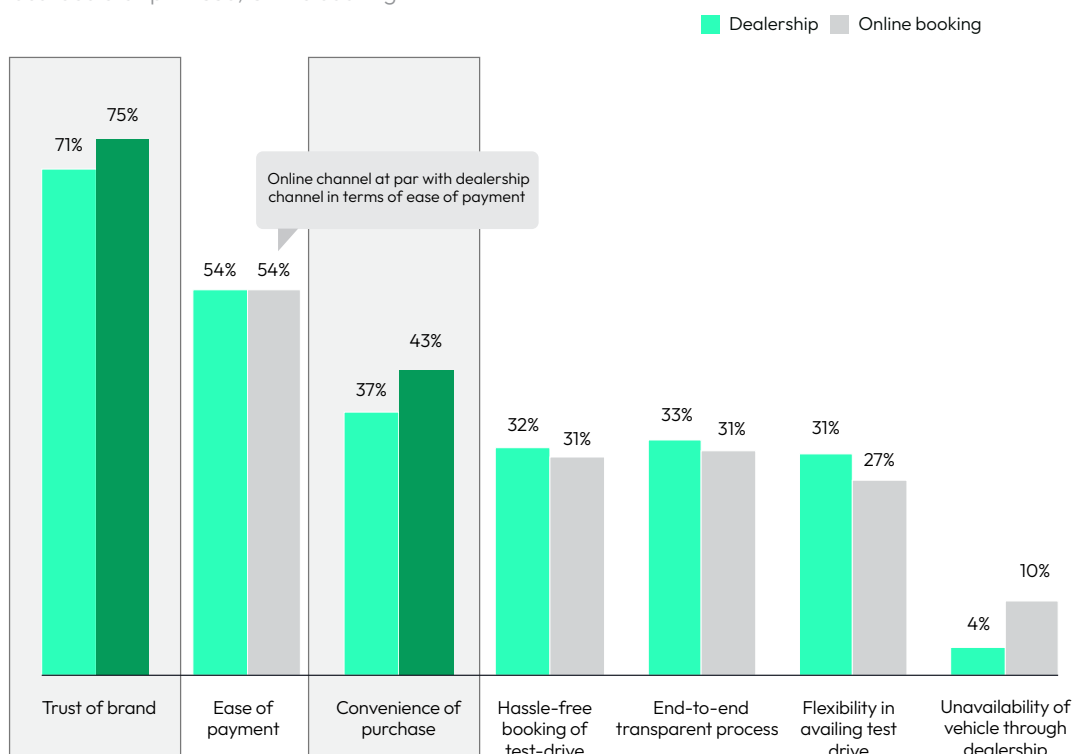

Source(s): Redseer Analysis, Consumer Surveys

Figure 26: Important factors for making a purchase decision

Increasing customer maturity around convenience and pan-India access to delivery is leading them to buy high value products online. The COVID-19 lockdown has also accentuated convenience-seeking behaviour, which has pushed consumers to believe that the online purchase journey for E2W will play a pivotal role in one- stop demand and supply matching.

## 7. Four A's of E2W eco System Growth

**“E2W ecosystem must work on the 4As, to achieve >80% electrification by 2030.”**

There is no doubt EVs are the future of driving and mobility, but they pose some challenges as well, these include rapid innovation and research specifically for India's use case and large-scale indigenous manufacturing for meeting the demand. While challenges to the electrification of the vehicle parc persist, the trend is irreversible, and opportunities worth fighting for also lay ahead.

The future of EVs in India can be summarized in 4As, that is Adaptability, Awareness, Availability and Affordability.

Key actions to be taken to realize target E2W penetration by 2030  
Descriptive

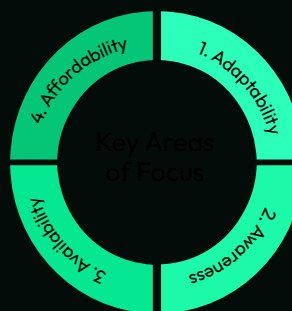

Source (s): Redseer Analysis

Figure 27: 4As for achieving E2W Penetration by 2030

### 1 Adaptability

Recent vehicle fires have made the customer wary of going for EVs, impacting sales volume. To address this, OEMs must come together to ensure no unsafe vehicle is rolled out on the road and there is a focus on India-specific innovation.

### 2 Awareness

E2Ws have innumerable benefits, not only for the environment but for individual consumers. In India, the imperative of shifting to electric mobility was recognised amidst the manifold problems created by fossil fuel use: their fast depletion, rising energy costs, the impact of motor vehicles on the environment, and concerns over climate change. It is important to create awareness about these benefits.

### 3 Availability

For a new product category like EV, customers need to experience the product, check the touch and feel of the product through offline customer touchpoints. Electric vehicles have been increasingly getting popular in India over the past few years. For E2W, an omnichannel play with an offline experience centre can be a cost-effective way of ensuring availability.

Further, optimisation of the supply chain would push the quick availability of EV products to the end user. Reduction of foreign dependence on raw materials will ease the complexity and cost of processing. And so, the time taken between the date of booking and delivery would be minimal.

### 4 Affordability

The EV market is growing at a healthy rate, driven mostly by the global desire and need to reduce the global warming influences contributed by internal combustion engines. Making the product affordable is now a key push to electric vehicles adoptability. In a motive to achieve the same, OEMs and Government are working towards making the product appealing to the consumers both in terms of cost and quality.

## Glossary

Keywords	Definition / Terms / Acronyms
Removable battery	The battery pack is self-contained and detachable from the E2W
Swappable battery	The battery pack is self-contained and detachable from the E2W and there exists infrastructure to swap the battery at swap stations
NMC Battery	NMC stands for a type of Li-battery with Nickel, Manganese & Cobalt as one of the electrodes
BLDC Motor	Brush-Less DC Motor delivers current through stator windings which generates a magnetic field to rotate permanent magnet of the rotor
IPM Motor	Interior-Permanent-Magnet AC motor in which magnets are imbedded in the rotor circumference
SPM Motor	Surface-Permanent-AC motor in which magnets are attached to the rotor circumference.
LFP Battery	Lithium-Ferro-Phosphate (LFP) is a type of Li-battery with ferro-phosphate based electrode
Regenerative braking	An energy recovery mechanism that slows down a moving vehicle by converting its kinetic energy into a form that can be either used immediately or stored until needed.
Walk assist	Feature in E2Ws, which enables the scooter to move at a slow speed of 2-3km/h to help a person to push it
Digital instrument cluster	A digital display unit in a vehicle to show speed, range, odometer, etc.
Combi brake	A braking system in which the rear brake is automatically applied when the front brake is applied
ABS	A Brake-assistance system which ensures the wheels do not lock up and slide while braking
Geo-Fencing	A GPS system in which the user can monitor if the vehicle has left the designated marked area
Reverse mode	Enables to scooter to slowly travel in the reverse direction
Telescopic Suspension	Type of front suspension in which the fork tube is on top of the slider
USD Suspension	Up-Side Down Suspension is a type of front suspension in which the slider is on top of the fork tube
Leading Link Suspension	Type of front suspension in which the wheel is suspended on a link (or links) with a pivot point aft of the wheel axle.
Single Fork suspension	Type of front suspension in which there is only a single sided front swingarm
Dual Shock suspension	Type of rear suspension in which there are 2 shock absorbers
Monoshock suspension	Type of rear suspension in which there is only 1 large shock absorber
Disc brakes	Braking system in which hydraulic fluid is used to press pads onto a metal rotor (Disc) to slow down using friction
Drum Brakes	Braking system in which centrifugal force is used to press pads against the walls of a drum to slow down using friction

## Authors



**Anil Kumar**  
Founder and CEO

Anil Kumar is the founder of Redseer Consulting. He has been part of engagements in Internet, Private Equity, Retail CPG and Healthcare among others. He specializes in growth and investment strategies. Anil is a believer of the data-driven approach in solving business problems. His consulting approach leverages Data IP, sector expertise and the client's core hypotheses. He holds a B.Tech from IIT-Delhi. He can be reached at [anil@redseer.com](mailto:anil@redseer.com)



**Aditya Agrawal**  
Partner

Aditya brings around 15 years of experience in manufacturing, commercial vehicles, and power generation industries. He's also worked briefly in Education and Financial Services. He is an expert in growth strategy, having advised global leaders on creating sustainable systems He can be reached at [aditya.agrawal@redseerconsulting.com](mailto:aditya.agrawal@redseerconsulting.com)



**Mukesh Kumar**  
Engagement Manager

Mukesh Kumar is the engagement manager at RedSeer and has 7 years of experience in growth strategy engagement across internet, education, healthcare, and consumer products clients across India, MENA, and North America. He holds a B.Tech from IIT Delhi. He can be reached at [mukesh@redseer.com](mailto:mukesh@redseer.com)



**Engagement Manager**

Jaladhi has 6+ years of consulting experience, in growth & investment strategy over India, MENA, & SEA . He has a diverse exposure to sectors ranging from automotive (EV & ICE), retail, FMCG to platform-based technology businesses; & specializes in identifying and conducting viability & diligence studies on new business models & trends. He can be reached at [jaladhisurati@redseer.com](mailto:jaladhisurati@redseer.com)



**Agrim Yadav**  
Associate Consultant

Agrim Yadav is associate consultant at Redseer and has experience in due diligence and growth strategy in Automobile, Ad-tech and e-Commerce sector.He has done his graduation and MBA from IIM Indore. He can be reached at [Agrim@redseerconsulting.com](mailto:Agrim@redseerconsulting.com)



**Nitika Jain**  
Associate Consultant

Nitika is an associate consultant in Redseer with 3+ years of experience, in Consulting & automobile R&D. She is a mechanical engineer and holds MBA degree from IIM Kozhikode She can be reached at [nitika.j@redseerconsulting.com](mailto:nitika.j@redseerconsulting.com)



**Sahana AV**  
Associate Consultant

Sahana is an Associate Consultant at Redseer and has 2 years of experience in commercial due diligence engagements across sectors including retail, ecommerce, logistics, entertainment, edtech, and foodtech across India and SEA. She has done her Bcom Honours from Shri Ram College of Commerce, Delhi University She can be reached at [Sahana@redseerconsulting.com](mailto:Sahana@redseerconsulting.com)

# Thank You



[query@redseer.com](mailto:query@redseer.com)

 [facebook.com/redseerconsulting](https://facebook.com/redseerconsulting)

 [twitter.com/Redseer](https://twitter.com/Redseer)

 [linkedin.com/company/Redseer-consulting](https://linkedin.com/company/Redseer-consulting)

**Solve. New.**

Disclaimer and confidentiality notice: This document contains information that may be confidential and proprietary. Unless you are the intended recipient (or authorized to receive this document for the intended recipient), you may not use, copy, disseminate or disclose to anyone the message or information contained in this document.